



# **CDC13 Specification**

**Cloud drive intelligent technology Co.,Ltd**

---

## Preface

Dear users:

To ensure better performance of your ebike, please read through the CDC13 instruction carefully before using it. We will inform you of all the details, including the installation and function setting of the display with the most concise words. Meanwhile, the specification will also help you to solve possible malfunction.

---

## Contents

1.Product brief instruction.....	3
2.Technical parameter .....	4
3.Appearance and dimension .....	5
4.Installation instructions .....	5
5.Button definition .....	6
6.Main interface instruction .....	7
(1) Turn on/off of front lights.....	7
(2)Pas level selection and 6Km/h implementation mode.....	7
(3)Batteryt indication .....	8
(4) Error code indication.....	8
7.General setting .....	9
(1) Speed unit setting .....	9
(2) Pass words input.....	9
(3) Wheel diameter setting .....	11
(4) Voltage setting .....	12
(5) Speed limit setting.....	13
(6) Version information indication.....	14
8.Schematic diagram for cable sequence of board terminal .....	15
9.Q&A.....	15
10.Quality assurance and warranty scope.....	15
Enclosed: Error code definition table.....	16

## 1. Product brief instructions

CDC13 products uses the 2.4-inch LCD color screen with a light and beautiful button. Frosted texture of black, beautiful appearance. The display interface bar frame is very clear, with backlight light sense design. Double side printed board, nylon buckle and ABS material shell, under the temperature ranging from -20°C to 60°C, which can ensure the good mechanical performance of the products.

CDC13 is a Multifunctional display that integrates 2.4 inch LCD. The one display can match 24V/36V/48V battery. At the same time it integrates 24V, 36V and 48V front lights switch function. With another CDBL\_C product of our company will greatly simplify the handlebar cable. The default sleep time of the display is 10min.



### CDC13 function Summary

- ◆ Total distance indication and riding distance indication
- ◆ Maximum speed and average speed
- ◆ Current speed indication
- ◆ Front lamp display
- ◆ PAS level selection
- ◆ Output power indication
- ◆ Battery residual capacity indication
- ◆ Error code definition
- ◆ Unit switch: kilometers or miles
- ◆ Blue tooth function(can be customized)
- ◆ 6Km/h implementation function
- ◆ Wheel diameter setting
- ◆ Voltage setting
- ◆ Speed limit setting

## 2. Technical parameter

Voltage of the power supply: 24V/36V/48V

Working current: 24V/35mA, 36V/27mA, 48V/24mA

Ambient temperature: -20°C to 60°C

Ambient humidity: 0 to 100%RH

Protection grade: IP65

Screen viewing angle: horizontal and vertical viewing angle both are 160°

### 3. Appearance and dimension

Appearance and dimension for display:

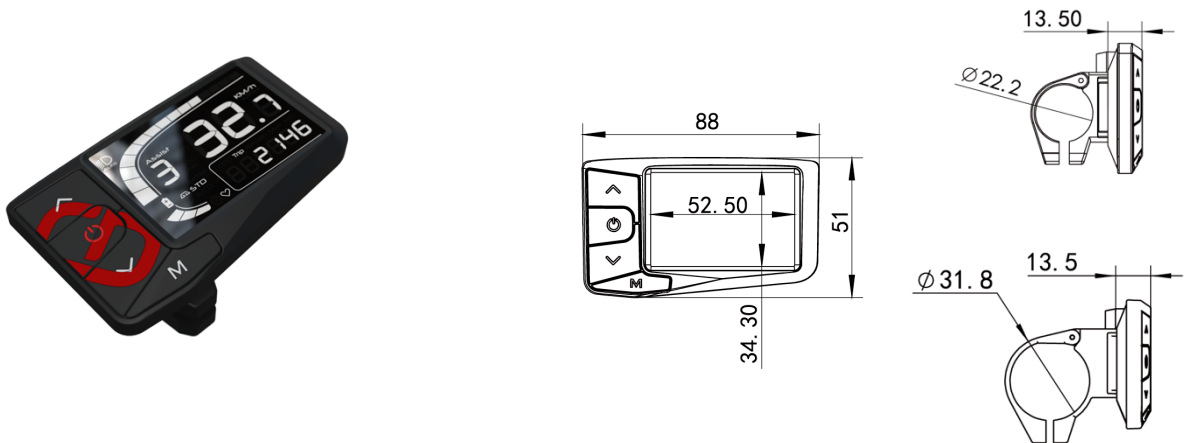





### 4. Installation instructions

The display CDC13 will be fixed on the handlebar, and then adjust the angle of view, and the button will be installed in the easily controlled position. Tighten the screws to finish the installation.



## 5. Button definition

button	operation	function
	holding 3S	1. When in the main interface, it will enter the setting menu;
	click	1. When in the setting interface, it will be confirmation function; 2. When in the pass words interface, it can switch the pass words digit;
	holding 3S	no
	click	1. When in the main interface, it will increase the level; 2. When in the setting interface, it will switch the options; 3. When in the pass words interface, it will increase the value of this pass word;
	holding 3S	1. When in the main interface, it will open on the walking function(will disappear when release the button);
	click	1. When in the main interface, it will reduce the lever; 2. When in the setting interface, it can switch options; 3. When in the pass words interface, it will reduce the value of this pass word;
	holding 3S	1. When in any interface, it will power off;
	click	1. When in the off state, it will power on; 2. When in the main interface, will open/close the front lamp;

## 6.Main interface instruction

The main interface of display CDC13 is shown as below figure:

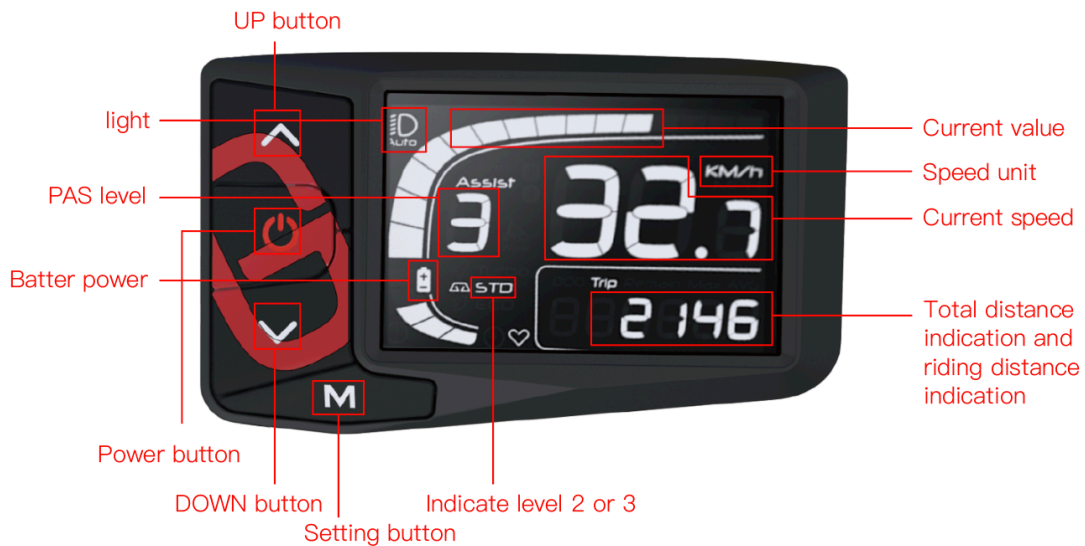

figure6

### (1) Turn on/off of front light





In the power-on state, click  button to turn the light and meanwhile it will show the light symbol on the display; Then click  button again, the light will be turned off.



figure6-1



## (2) Pas level selection and 6Km/h implementation mode

In the power-on state, clicking  or  button can switch the pas level and change the power of motor output. The default output power of the display is level 0 to level 5. Holding the  button will enter 6Km/h implementation mode.

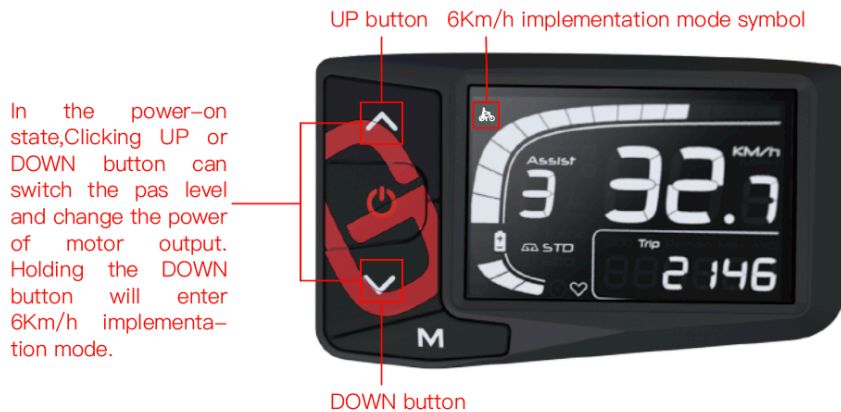

figure6-2

## (3) Battery indication

There will be five bars shown on the screen if the battery capacity is high enough. The less bars will show on the screen if the capacity of the battery is less. When the battery is almost dead, the last bar will flash. You need to charge the battery immediately. As shown in figure:



figure6-3

#### (4) Error code indication

When the ebike drive system fails, it will stop working, and the display will show the error code on the screen automatically and flash. The error code will not stop showing on the screen until the problem is solved, even though turn off the display.

The reason for the error is shown in the attachment of error code definition table.



figure6-4

### 7.General setting

#### (1) Speed unit setting

In the power-on state, holding **M** button for 3s will enter the speed unit setting interface. Then clicking **^** or **v** button can switch the speed unit. If there's no operation in 10s, the dashboard will automatically exit the speed setting interface.

The speed unit switching is shown in figure7-1.

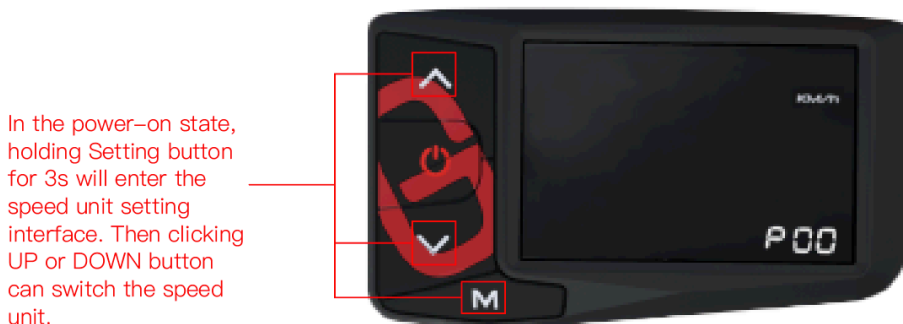

figure7-1

## (2) Pass words input

After finish the speed unit setting, clicking **M** button will enter the pass words interface, as shown in figure 7-2. The default pass words of the display is 1919.



figure 7-2

a. Click  $\wedge$  or  $\vee$  button to set the first password number. The number will be changed from 0 to 9 or 9 to 0 step by step when you click  $\wedge$  or  $\vee$  button, as shown in figure 7-2-a.



figure 7-2-a

b. To confirm the first password number, click **M** button, and it will enter the second password setting interface. Each time you click  $\wedge$  or  $\vee$  button, the number changes from 0-9 or 9-0 step by step, as shown in figure 7-2-b.



figure 7-2-b

c. To confirm the second password number, click **M** button, and it will enter the third password setting interface. Each time you click  $\wedge$  or  $\vee$  button, the number changes from 0-9 or 9-0 step by step, as shown in figure 7-2-c.



figure 7-2-c

d. To confirm the third password number, click **M** button, it will enter the fourth password setting interface at the same time. Each time you click  $\wedge$  or  $\vee$  button, the number changes from 0-9 or 9-0 step by step, as shown in figure 7-5-d.



figure 7-5-d

To confirm the fourth password number, click **M** button and enter the advanced setting interface. The first one is wheel diameter setting.

### (3) Wheel diameter setting

After input the correct pass words, you can see the below options, as shown in figure 7-3(it shows 27C in the picture)

By clicking **^** or **v** button, you can select the corresponding wheel diameter to ensure the accuracy of display speed and distance indication.

轮径值
12寸 (957mm)
16寸 (1272mm)
18寸 (1350mm)
20寸 (1590mm)
22寸 (1770mm)
24寸 (1948mm)
26寸 (2072mm)
27寸 (2210mm)
28寸 (2260mm)
29寸 (2313mm)

After input the correct pass words, will enter the wheel diameter setting interface. By clicking UP or DOWN button, you can select the corresponding wheel diameter to ensure the accuracy of display speed and distance indication.



figure 7-3

### (4) Voltage setting

After finishing the wheel diameter setting, clicking **M** button will show you the voltage value. The display can match 24V/33V/36V/48V/52V battery. By clicking **^** or **v** button, select the corresponding voltage value and then click **M** button to confirm, meanwhile the display will exit the voltage setting interface, as

shown in figure 7-4(the default voltage is 36V)

After finishing the wheel diameter setting, clicking UP button will show you the voltage value. By clicking UP or DOWN button, select the corresponding voltage value and then click SET button to confirm.



figure 7-4

### (5) Speed limit setting

After finishing the voltage setting, clicking **M** button will enter the speed limit setting interface and click  $\wedge$  or  $\vee$  button to set the limit speed, which maximum is 40Km/h. Then click **M** button to confirm it, meanwhile the display will

Clicking UP or DOWN button can change the limit speed and click SET button to confirm it.



exit automatically, as shown in figure 7-5(can be customized).

figure 7-5

## (6) Version information indication

After finishing the speed limit setting, click  button, it will enter into the software version information interface. We can better identify the system state by reading the software version to find out the original source code to better serve you.

The version information is shown in figure 7-6.



figure 7-6

## 8.Schematic diagram for cable sequence of board terminal

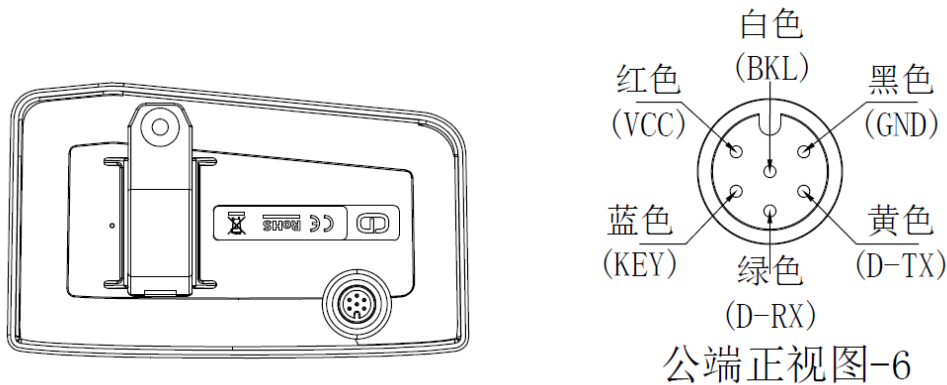

Figure8-1

## 9.Q&A

Q: Why the display is not able to start up?

A: Check the connector that between display and controller.

Q: How to deal with the error code?

A: Fix it to the maintenance place immediately. If it cannot be resolved, you can go to the electric vehicle repair points repair it in a timely manner.

## 10.Quality assurance and warranty scope

### Warranty

(1) Under warranty, our company will shoulder the responsibility to provide limited warranty to any faults caused by the quality of the product under normal use.

(2) The warranty period lasts for 18 months since the date of purchase.



## Other items

The following items does not belong to warranty scope

- (1) Disassembly or modification without authorization.
- (2) Malfunction or damage caused by the misuse or improper installation and debugging by the users or the third party.
- (3) Shell scratch or breakage after leaving the factory.
- (4) Wiring scratch or breakage.
- (5) Malfunction or damage caused by the force majored (fire, earthquake etc. ) or natural disasters (lightening etc.)
- (6) Beyond Warranty period.

## Enclosed: Error code definition table

<b>error code</b>	<b>definition</b>
2	Over current protection is checked by the controller. Check whether the connectors of three-phase power cable and the hall signal connectors are badly connected . There is something wrong with the controller or motor if the problem is still present after reconnect the connectors.

3	<p>The controller can't properly drive the motor : Check whether the connectors of three-phase power cable and the hall signal and the power supply connectors are badly connected .Or there is not enough power to drive the system than 2S, such as climbing or the wheel is stuck . There is something wrong with the controller or motor if the problem is still present after reconnect the connectors.</p>
4	<p>Battery voltage is too low to protect, under voltage protection.</p>
5	<p>After the system power on , check whether the brake is working properly.If the brake signal is less than 0.75V for very a long time, there is something wrong with the brake.</p>
6	<p>Check whether the hall commutation signal of the motor is faulty or not. Check the connector of the motor's hall signal cable is disconnected or not. The hall of motor maybe broken if the problem is still present after reconnect the connectors.</p>
7	<p>After the system power on, check whether the throttle is out of control or the throttle signal is less than 0.75V ,or customer turns the throttle before the system works, the error can be solved after throttle is reset.</p>
8	<p>The controller is broken.</p>

A/10	The display and the controller have communication problems , the yellow cable is not connected.
D/13	The controller program is wrong or the 5V is wrong, check whether the brake signal short with 5V.
F/15	The display and the controller have communication problems, the green cable is not connected, or the communication protocol doesn't match.
<p>If there is something wrong with the 5 cables between the controller and display:</p> <p>(1)If the display can't power on and there is no display on the screen, the reasons may be: the power supply connector between controller and battery is not connected well or there is something wrong with the cable (the red, black ,blue cable of any 1 cables) between display and controller.</p> <p>(2)If the display is turned on, but after working 3 seconds stop working. The reasons may be: the connection (the green, yellow cable) between the display and the controller is open circuit.</p> <p>The error code explanation is based on the correct system from</p> <p><b>Cloud drive intelligent technology Co.,Ltd</b></p>	